

DIGI RAKUE

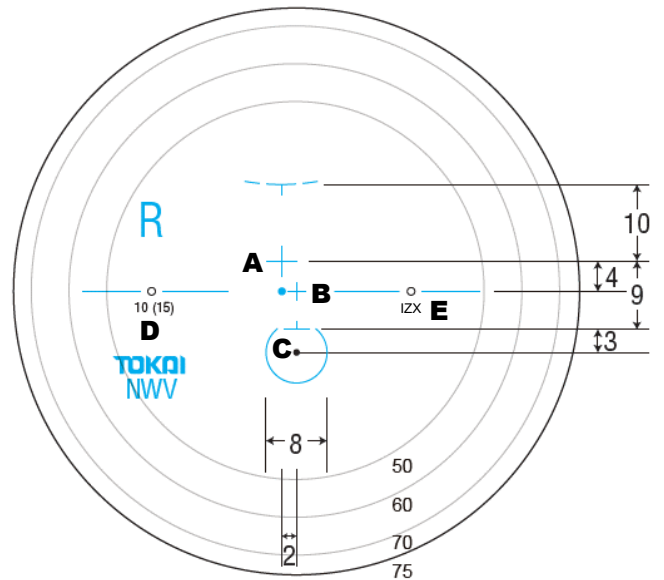
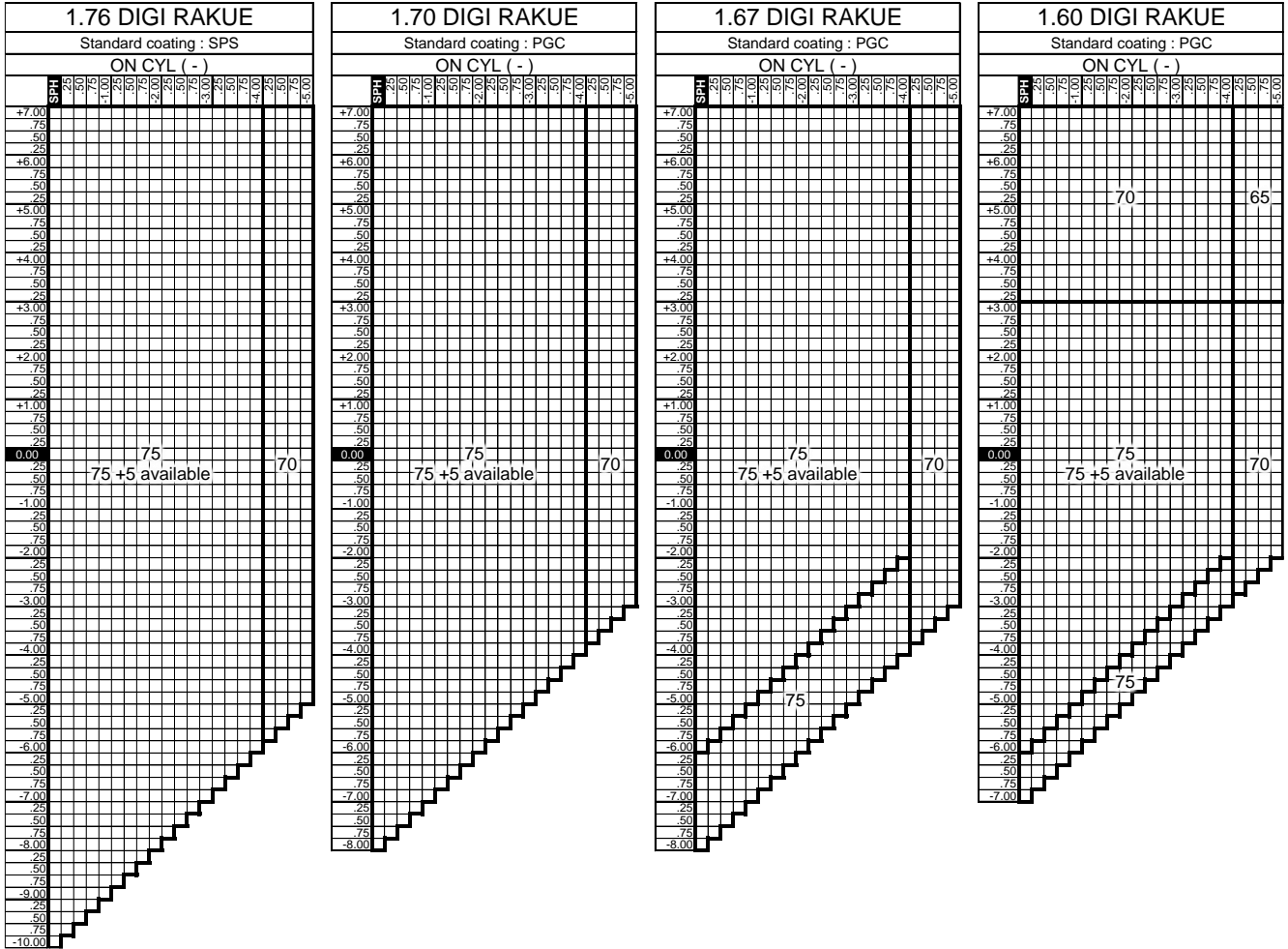

Specifications		Specifiable range / Availability
Prescription	Size reduction	by 50mm Min : only (+), 1mm step
	Prism	Up to 3 prism
	Decentration	Not available
	Base curve selection	Available
Type	Power digression	Type1 = -1.00D, Type2 = -1.50D
Frame data	Slice (Frame shape required)	Available for plus & mixed power lenses
	Fine edge processing	Available (Less S+C = -3.00 :Not available) Depending on direction of AXIS or design type, it may not be possible to manufacture.

Mark	Index
I	ZX 1.76
	JX 1.70
	UX 1.67
	HX 1.60

Lens mark	
A	Fitting point EP is 2.0mm from Geometrical center on the ear side.
B	Geometrical center. Size specification reference center Area to measure the prismatic power
C	Area to measure the near vision power
D	Addition (Minus)
E	Identification mark